



H32AQ

Video SoC for Automotive

Overview

Ambarella's H32AQ SoC combines image / video processing, 6MP30 video encoding, and a quad-core processor in a single, low-power design making it an ideal choice to power the next generation of automotive cameras / video recorders. Fabricated in a 10 nm process technology, it achieves an industry-leading combination of low-power and high-performance. It is an ideal platform for implementing multi-channel digital video recorders, single or multi-channel electronic mirror, with recording, driver / in-cabin monitoring cameras, and more.

H32AQ uses a next generation image signal processor (ISP) to deliver outstanding imaging in low-light conditions, while its high dynamic range (HDR) processing extracts maximum image detail in high contrast scenes. The chip implements a highly-efficient distortion correction block which allows support of ultra-wide angle and fisheye lenses. Its flexible hardware architecture allows processing of videos from multiple sensors simultaneously, enabling a lower overall system BOM cost. H32AQ supports applications that require multiple encoded streams that are optimized for storage and streaming (WiFi / BLE).

H32AQ provides ample host CPU performance to implement application code and other lightweight computer vision algorithms such as localization and map building (SLAM) or neural networks.



The H32AQ chip targets automotive camera designs

Key Features

Flexible Low-Power Platform

- Quad-core Arm® Cortex®-A53 CPU up to 756 MHz
- Multiple OS Support: ThreadX, Linux, ThreadX + Linux
- 10 nm low-power CMOS process

Advanced Image Processing

- Multi-sensor support
- Multi-exposure line-interleaved HDR sensors with a dynamic range greater than 120 dB
- Hardware dewarping engine
- Electronic image stabilization (EIS)
- Superior low-light processing
- 3D motion-compensated temporal filtering (MCTF)
- RRGB / RCCB / RCCC / RGB-IR / monochrome sensor support

High-Efficiency Video Encoding

- H.265 and H.264 video compression
- Flexible multi-streaming capability
- 6MP30 video performance
- Multiple CBR and VBR control modes
- Smart H.264 and H.265 encoder algorithms

Target Applications

- Multi-channel drive recorder
- Single- / multi-channel electronic mirror
- Driver monitoring system (driver distraction / drowsiness detection)

Block Diagram

The diagram below illustrates a design based on the Ambarella H32AQ device.

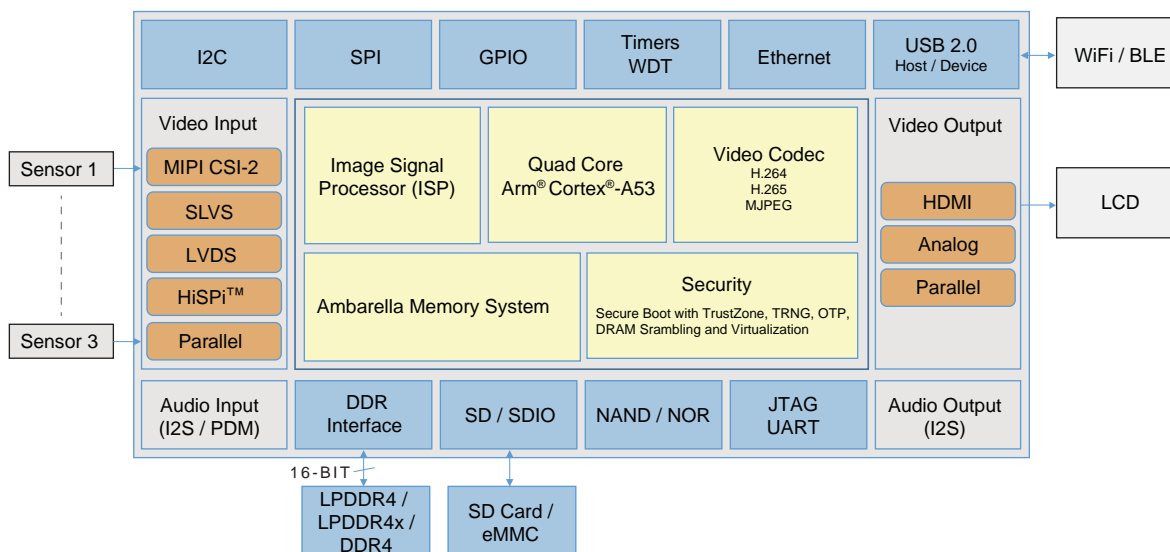

General Specifications

Processor Cores

- Quad-core Arm® Cortex®-A53 up to 756 MHz
- 32KB / 32KB I/D and 1 MB L2 Cache
- NEON™ SIMD and FPU acceleration
- Secure boot with TrustZone®, TRNG, OTP, DRAM scrambling and virtualization
- Ambarella image signal processor
- AVC / HEVC video codec

Video Input

- Single, dual, or triple sensor inputs with independent ISP configuration
- Sub-LVDS / MIPI CSI-2 / SLVS / HiSPi™
- 16-bit parallel LVCMOS (BT.601 / 656)

Video Output

- HDMI® 2.0 including PHY with CEC support
- PAL / NTSC composite SD video out
- 16-bit parallel LVCMOS (BT.601)

CMOS Sensor Processing / Image Processing

- Lens shading correction
- Multi-exposure HDR (line-interleaved sensors)
- 3D motion-compensated temporal filtering (MCTF)
- RGGB / RCCB / RCCC / RGB-IR / monochrome sensor support
- 3-axis electronic image stabilization (EIS)
- Adjustable AE / AWB
- Lens distortion correction (LDC) for wide angle lens
- LED flicker compensation for LED sources
- Gamma compensation and color enhancement
- Vignetting compensation
- Dynamic range (WDR and HDR) engine
- OSD engine, overlays, privacy mask
- Crop, mirror, flip, 90°/ 270° rotation
- Defect pixel correction
- Chromatic aberration correction

Video Encoding

- H.265 MP L5.0, H.264 MP/HP L5.1 and MJPEG
- 6MP30 maximum encoding performance
- Simultaneous encoding and streaming
- Multi-stream and multi-channel encoding
- Still capture (picture in video or PIV)
- Flexible GOP configuration with I, P, and B frames
- Multiple CBR and VBR control modules

Memory Interfaces

- LPDDR4 / LPDDR4x / DDR4 up to 1.6 GHz, 16-bit data bus, and up to 1 GB capacity
- Three SD controllers
- Boot from SPI SLC NAND with BCH / SPI NOR / USB / eMMC
- Single- / dual- / quad-SPI NOR and SPI NAND

Peripheral Interfaces

- 10 / 100 / 1000 Ethernet with RMII / RGMII
- USB 2.0 port configurable for host / device
- Multiple I²S / PDM, SSI / SPI, I2C, and UART
- Multiple GPIO ports, PWM, IR, and ADC
- Watchdog timer, multiple general purpose timers, and JTAG

Physical

- 10 nm low-power CMOS
- Operating temperature -40°C to +105°C
- FC VFBGA package with 288 balls, 11x12 mm, 0.65 mm pitch
- Automotive qualified (AEC-Q100 Grade-2)

H32AQ Camera Development Platform

The H32AQ camera development platform contains the necessary tools, software, hardware, and documentation to develop a small form factor camera.

Evaluation Kit (EVK)

- H32AQ main board with connectors for sensor / lens board, peripherals
- Sensor board: OmniVision, Sony, and others
- Datasheet, BOM, schematics, and layout
- Reference application with C source code

Software Development Kit (SDK)

- ThreadX / Linux / ThreadX + Linux with patches, drivers, tools, and application source code
- Royalty-free libraries for ISP, 3A, dewarp, and codecs
- Image tuning and manufacturing calibration tools
- Detailed documentation, including a programmer's guide and more

Contact www.ambarella.com/about/contact/inquiries.html

Copyright Ambarella International LP. All rights reserved. Ambarella and the Ambarella logo are trademarks of Ambarella International LP. All other brands, product names, and company names are trademarks of their respective owners. The information in this document is believed to be reliable, but may project preliminary functionality not yet available. Ambarella makes no guarantee or warranty concerning the accuracy and availability of said information and shall not be responsible for any loss or damage whatever nature resulting from the use of, or reliance upon it. Ambarella does not guarantee that the use of any information contained herein will not infringe upon patent, trademark, copyright, or other rights of third parties. Ambarella reserves the right to make changes in the product and/or its specifications presented in this publication at any time without notice.